

Name _____ Date _____ Period _____

- In figure to right, if the arm makes a 30° angle with the horizontal and a torque of $18 \text{ m} \cdot \text{N}$ is to be produced, what force must the biceps muscle supply if the muscle attaches 3.0 cm from the elbow?
- The drain plug on a car's engine has been tightened to a torque of $25 \text{ m} \cdot \text{N}$. If a 0.15-m -long wrench is used to change the oil, what is the minimum force needed to loosen the plug?

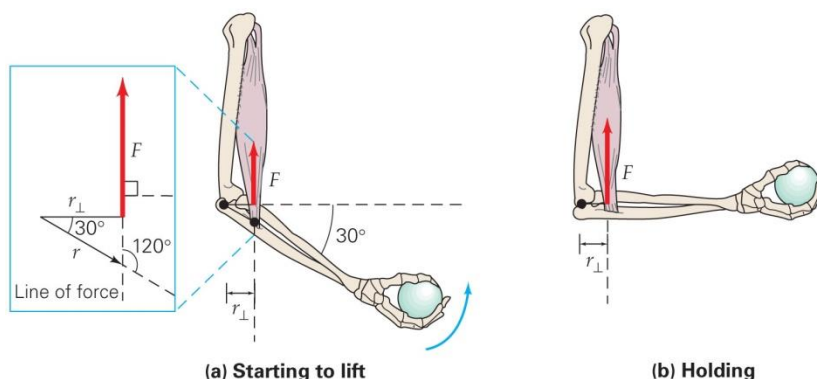

- In problem 2, due to limited work space, you must crawl under the car. The force thus cannot be applied perpendicularly to the length of the wrench. If the applied force makes a 30° angle with the length of the wrench, what is the force required to loosen the drain plug?
- How many different positions of stable equilibrium and unstable equilibrium are there for a cube? Consider each surface, edge, and corner to be a different position.
- Two children are sitting on opposite ends of a uniform seesaw of negligible mass. (a) Can the seesaw be balanced if the masses of the children are different? How? (b) If a 35-kg child is 2.0 m from the pivot point (or fulcrum), how far from the pivot point will her 30-kg playmate have to sit on the other side for the seesaw to be in equilibrium?
- A uniform meter stick pivoted at its center, has a 100-g mass suspended at the 25.0-cm position. (a) At what position should a 75.0-g mass be suspended to put the system in equilibrium? (b) What mass would have to be suspended at the 90.0-cm position for the system to be in equilibrium?

- Telephone and electrical lines are allowed to sag between poles so that the tension will not be too great when something hits or sits on the line. (a) Is it possible to have the lines perfectly horizontal? Why or why not? (b) Suppose that a line were stretched almost perfectly horizontally between two poles that are 30 m apart. If a 0.25-kg bird perches on the wire midway between the poles and the wire sags 1.0 cm , what would be the tension in the wire?

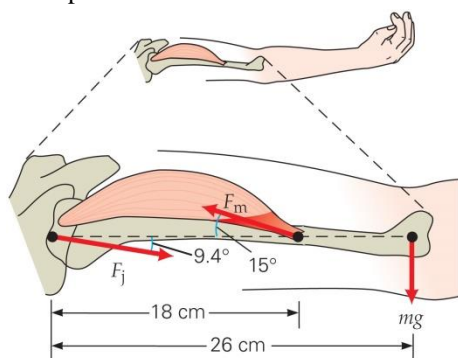

- In figure to left, what is the force F_m supplied by the deltoid muscle so as to hold up the outstretched arm if the mass of the arm is 3.0 kg ? (F_j is the joint force on the bone of the upper arm—the humerus.)

- In Figure b at top of page, determine the force exerted by the bicep muscle, assuming that the hand is holding a ball with a mass of 5.00 kg . Assume that the mass of the forearm is 8.50 kg with its center of mass located 20.0 cm away from the elbow joint (the black dot in the figure). Assume also that the center of mass of the ball in the hand is 30.0 cm away from the elbow joint. (The muscle contact is 4.00 cm from the elbow joint, Example 8.2.)
- A bowling ball (mass 7.00 kg and radius 17.0 cm) is released so fast that it skids without rotating down the alley (at least for a while). Assume the ball skids to your right and the coefficient of sliding friction between the ball and the lane surface is 0.400 . (a) What is the direction of the torque exerted by the friction on the ball about the center of mass of the ball? (b) Determine the magnitude of this torque (again about the ball's center of

mass).

11. A variation of Russell traction (figure to right) supports the lower leg in a cast. Suppose that the patient's leg and cast have a combined mass of 15.0 kg and m_1 is 4.50 kg. (a) What is the reaction force of the leg muscles to the traction? (b) What must m_2 be to keep the leg horizontal? (c)
12. In doing physical therapy for an injured knee joint, a person raises a 5.0-kg weighted boot as shown below. Compute the torque due to the boot for each position shown

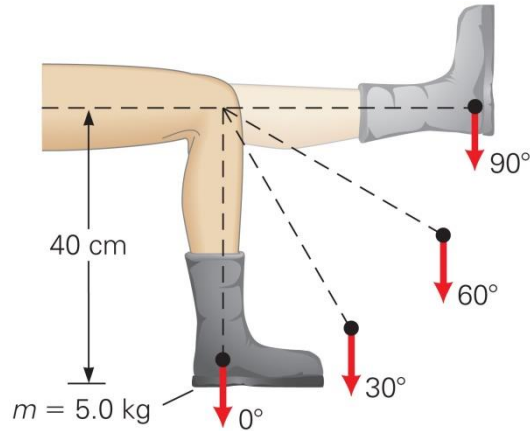
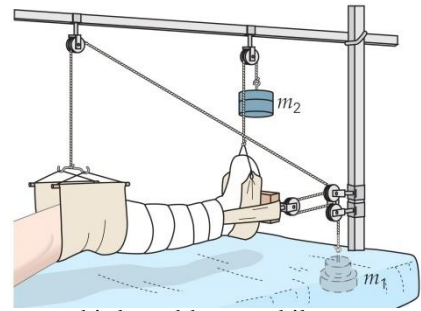

13. An artist wishes to construct a birds-and-bees mobile, as shown in figure below. If the mass of the bee on the lower left is 0.10 kg and each vertical support string has a length of 30 cm, what are the masses of the other birds and bees? (Neglect the masses of the bars and strings.)

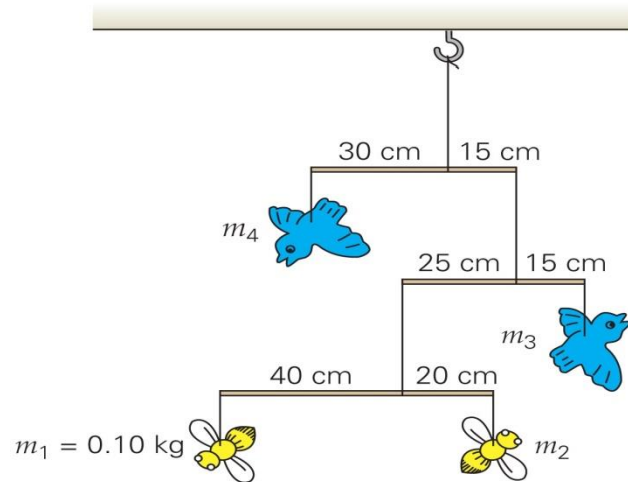

14. The location of a person's center of gravity relative to his or her height can be found by using the arrangement shown in figure below. The scales are initially adjusted to zero with the board alone. (a) Would you expect the location of the center of gravity to be (1) midway between the scales, (2) toward the scale at the person's head, or (3) toward the scale at the person's feet? Why? (b) Locate the center of gravity of the person relative to the horizontal dimension.

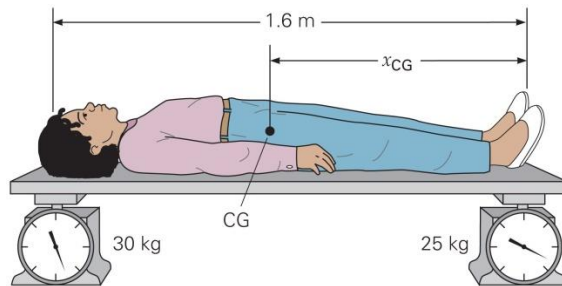

15. (a) How many uniform, identical textbooks of width 25.0 cm can be stacked on top of each other on a level surface without the stack falling over if each successive book is displaced 3.00 cm in width relative to the book below it? (b) If the books are 5.00 cm thick, what will be the height of the center of mass of the stack above the level surface?
16. If four meter sticks were stacked on a table with 10 cm, 15 cm, 30 cm, and 50 cm, respectively, hanging over the edge, as below, would the top meter stick remain on the table?

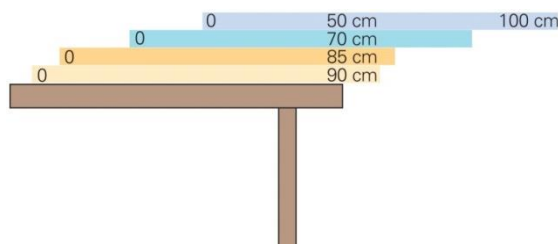

17. A 10.0-kg solid uniform cube with 0.500-m sides rests on a level surface. What is the minimum amount of work necessary to put the cube into an unstable equilibrium position?
18. While standing on a long board resting on a scaffold, a 70-kg painter paints the side of a house, as shown in figure below. If the mass of the board is 15 kg, how close to the end can the painter stand without tipping the board over?

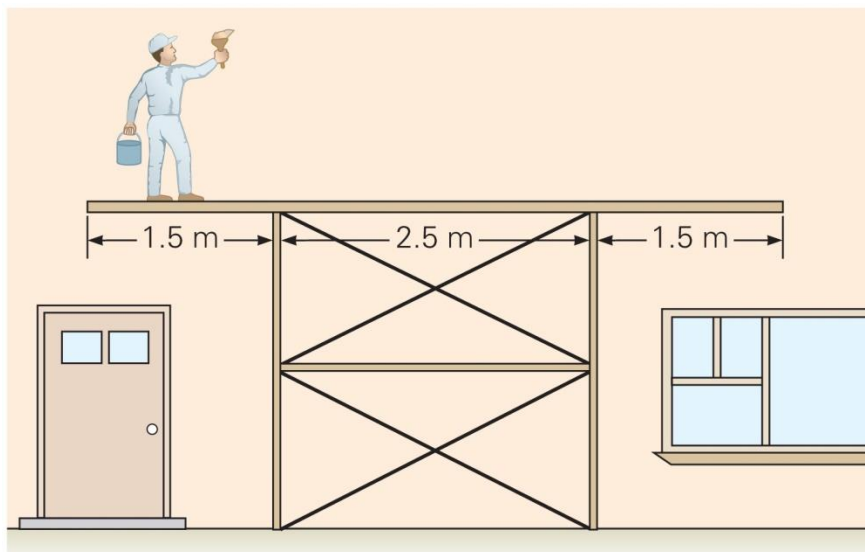

19. Suppose that the board in figure above were suspended from vertical ropes attached to each end instead of resting on scaffolding. If the painter stood 1.5 m from one end of the board, what would the tensions in the ropes be?
20. A mass is suspended by two cords as shown in figure to the right. What are the tensions in the cords?
21. If the cord attached to the vertical wall in the same figure as question 20 were horizontal (instead of at a 30° angle), what would the tensions in the cords be?

