

Name _____ Date _____ Period _____

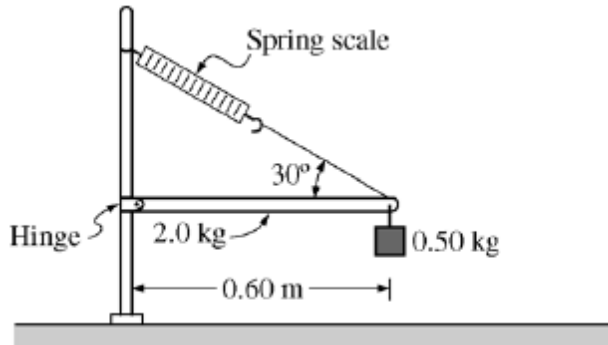

The horizontal uniform rod shown above has length 0.60 m and mass 2.0 kg. The left end of the rod is attached to a vertical support by a frictionless hinge that allows the rod to swing up or down. The right end of the rod is supported by a cord that makes an angle of 30° with the rod. A spring scale of negligible mass measures the tension in the cord. A 0.50 kg block is also attached to the right end of the rod.

(a) On the diagram below, draw and label vectors to represent all the forces acting on the rod. Show each force vector originating at its point of application.



(b) Calculate the reading on the spring scale.

(c) Calculate the magnitude of the force exerted by the hinge on the rod